

optibelt *ALPHA Special / ALPHA SRP*

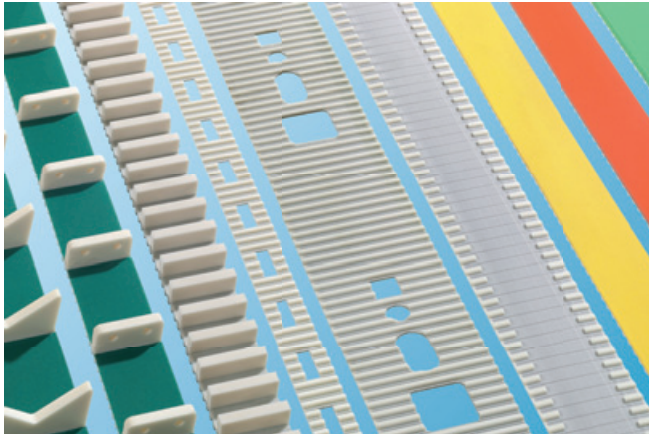

Coatings

Optibelt special timing belts may be made with special top surfaces, cleats, lugs or fins using either a moulding process (as Optibelt ALPHA SRP belts) or using Optibelt ALPHAflex or Optibelt ALPHA linear/ALPHA V as the base belt with the top surfaces added mechanically.

Due to the huge variety of coatings and finishing possibilities plus the properties of the timing belt or belting, innovative solutions can be developed in the field of conveying technology.

Mechanical finishing

In order to make the Optibelt ALPHA Special timing belts most suitable for the required task, the following additional processing steps are available:

- Ground belt top surface
- Ground belt width
- Machined grooves longitudinally in the belt top surface
- Machined grooves longitudinally in the tooth side
- Remove individual teeth
- Pierce toothed belts
- Separate coatings
- Milled grooves in the belt top surface/coating
- Optibelt ALPHA Special timing belts for conveying purpose
- Available with top surface, lugs or cleats, or mechanical machined
- For innovative drive solutions

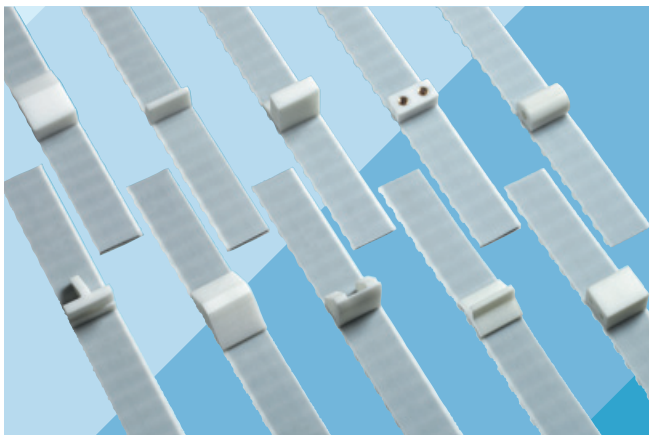
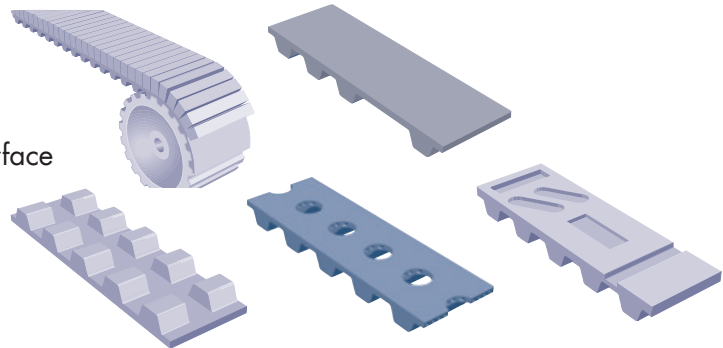

Cleats

Optibelt ALPHA V Special/ALPHAflex special timing belts have cleats or lugs added separately to the base belt Optibelt ALPHA V or Optibelt ALPHAflex. Optibelt ALPHA SRP belts are moulded endless belts where the cleats, lugs or fins are a part of the design of the outer part of the mould. Should the present product range not provide a shape or pitch of the cleat or lug appropriate to your requirements, it can be cost-effectively manufactured/adjusted according to your specifications.

On this page, you will see an extract from our standard product range. We would be delighted to support you to help solve your conveying problems.